

MultiModem[®] EDGE

Wireless Modem

MTCBA-E

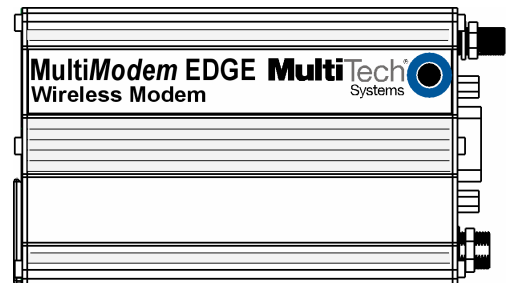

User Guide



**MultiModem® EDGE
External Wireless Modem
Model MTCBA-E
P/N S000381D, Revision D**

Copyright

This publication may not be reproduced, in whole or in part, without prior expressed written permission from Multi-Tech Systems, Inc. All rights reserved.

Copyright © 2006 by Multi-Tech Systems, Inc.

Multi-Tech Systems, Inc. makes no representation or warranties with respect to the contents hereof and specifically disclaims any implied warranties of merchantability or fitness for any particular purpose.

Furthermore, Multi-Tech Systems, Inc. reserves the right to revise this publication and to make changes from time to time in the content hereof without obligation of Multi-Tech Systems, Inc., to notify any person or organization of such revisions or changes. Check Multi-Tech's Web site for current versions of our product documentation.

Revision History

Revision	Date	Description
A	08/05/05	Initial Release
B	10/13/05	Changed temperature range, added humidity rating, changed modem maintenance, and warranty chapter.
C	04/25/06	Added automotive replacement fuse info, and changed Reset pin to 20msec.
D	06/14/06	Added AT command examples. Reorganized the guide.
	06/16/06	Changed Operating Temperature and added Storage Temperature.
	06/21/06	Changed location of Activation Notices. Added the dimensions of the fused DC power cable and how to change the fuse. Added note about current documentation on Web site.
	06/28/06	Added additional troubleshooting questions.

Trademarks and Logos

Multi-Tech and the Multi-Tech logo are trademarks of Multi-Tech Systems, Inc. MultiModem is a registered trademark of Multi-Tech Systems, Inc. Windows is a registered trademark of Microsoft in the U.S. and other countries. Other trademarks and trade names mentioned in this publication belong to their respective owners.

World Headquarters

Multi-Tech Systems, Inc.
2205 Woodale Drive
Mounds View, Minnesota 55112
(763) 785-3500 or (800) 328-9717
Fax: (763) 785-9874
Internet Address: <http://www.multitech.com>

Technical Support

Country	By Email	By Phone
France:	support@multitech.fr	+(33) 1-64 61 09 81
India:	support@multitechindia.com	+91 (124) 2340780
Europe, Asia, Africa:	support@multitech.co.uk	+(44) 118 959 7774
U.S., Canada, all others:	support@multitech.com	(800) 972-2439 or +(763) 717-5863

Contents

Chapter 1 – Product Description and Specifications	4
Product Description.....	4
Features.....	4
Application Overview.....	5
Application Types.....	5
Benefits/Features in Applications.....	5
Safety.....	6
General Safety.....	6
RF Interference Issues.....	6
Vehicle Safety.....	6
Maintenance of Your Modem.....	6
Your Responsibility.....	6
Package Contents.....	7
Specifications.....	8
General Specifications.....	8
Electrical Characteristics.....	8
Input/output electrical characteristics for external connections.....	8
Antenna/RF Specifications.....	8
Interfaces.....	9
LEDs.....	9
RS232 15-Pin Connector Pinout.....	9
AT Command Information.....	9
Chapter 2 – Activation and Installation	10
Step 1 – Activate Your Wireless Account.....	10
Step 2 – Insert the SIM Card into the Holder.....	10
Step 3 – Hook up the Antenna, Serial Cable, and Power.....	11
Step 4 – Optional – Attach the Modem to a Flat Surface.....	13
Step 5 – Install the Modem Driver.....	14
Chapter 3 – Using Your Wireless Modem	15
Phone Number for the Wireless Modem.....	15
Examples of Useful AT Commands.....	15
Verify Signal Strength.....	15
Checking Network Registration and Roaming Status.....	15
Checking the Modem’s Identity.....	15
Establishing a Voice Call.....	16
Establishing a Circuit-Switched Data Call for a Point-to-Point Connection.....	16
Answering a Circuit-Switched Data (CSD) Connection.....	16
Using Short Message Service (SMS).....	17
SMS Examples.....	18
Internet Access.....	19
Connecting to the GPRS/EDGE Network for Internet Access.....	19
Mobile PhoneTools.....	21
Chapter 4 – Troubleshooting and Frequently Asked Questions	22
Troubleshooting Examples.....	22
Frequently Asked Questions.....	23
Chapter 5 – Reference Information	25
Wireless Modem Reference Information.....	25
General.....	25
Data Cable Diagram – No Voice.....	25
Data Cable Diagram – with Voice.....	26
Fused DC Power Cable Dimensions.....	26
How to Change the Fuse.....	26
Appendix A – Warranty and Repairs	27
Appendix B – Waste Electrical and Electronic Equipment (WEEE) Statement	29

Chapter 1 – Product Description and Specifications

Product Description

The MultiModem® EDGE wireless modem delivers some of the fastest cellular wireless data speeds by utilizing EDGE technology. It allows users to connect to the Internet and send and receive data up to three times faster than possible with an ordinary GSM/GPRS network making it ideal for highly data-intensive multimedia applications. Based on industry-standard open interfaces, the MultiModem EDGE wireless modem is equipped with quad-band GSM, which means it can be used worldwide on all existing GSM networks. It also supports mobile originated short message service (SMS) and mobile-terminated SMS. This ready-to-deploy, standalone modem allows developers to add wireless communication to products with a minimum of development time and expense. A Note About Documentation: Multi-Tech Systems, Inc. reserves the right to revise this publication and to make changes from time to time in the content hereof without obligation of Multi-Tech Systems, Inc., to notify any person or organization of such revisions or changes. Check Multi-Tech's Web site for current versions of our product documentation.

Features

• EDGE (E-GPRS) Class 10 operation
• GPRS Class 12
• Quad-band GSM 850/900/1800/1900 MHz
• Packet data rates up to 240K bps (coding scheme MCS-9, LLC layer, 4 time slots)
• Embedded TCP/IP stack
• Circuit-switched data up to 14.4K bps non-transparent
• Short Message Services (SMS) text and PDU, point-to-point MO & MT, cell broadcast
• 50 ohm SMA female antenna connector
• Standard 3V SIM receptacle
• Desktop or panel mounting
• Group 3 Fax Class 1
• RS-232 interface
• AT command compatible
• Carrier approved
• Numerous LEDs provide operational status
• Voice features include Half rate (HR), Full rate (FR), Enhanced full rate (EFR), and Adaptive multi rate (AMR) as well as hands-free echo cancellation and noise reduction.
• Two year warranty
• Certifications CE Mark, R&TTE EMC: FCC Part 2, 15 Class A, 22, 24; EN 55022; EN 55024 Safety: cUL, UL 60950; EN 60950 Network: PTCRB

Application Overview

Application Types

With circuit switched data rates up to 14.4K bps, the MultiModem® EDGE Wireless Modem is targeted at applications that periodically need to send or receive data over a wireless network. It is an ideal solution for:

Automated machine-to-machine (M2M)
Public-Safety/Emergency Services
Public Transit
Remote Industrial/Medical/Environmental Monitoring
Remote Diagnostics
Security Systems
Telemetry/Remote-Metering
Vehicle-Tracking / Fleet Management / AVL
Note: The Wireless MultiModem must be mounted with at least 8 inches (20 cm) of clearance from the human body.

Benefits/Features in Applications

Short Development Time. The MultiModem EDGE Wireless Modem can make your device, machine, or system, communication-ready without hardware design changes. It is a complete, ready-to-deploy wireless modem. Because PTCRB and RF approvals have already been secured, regulatory delays will not impede the time-to-market for products that use the EDGE MultiModem.

Short Message Services. The MultiModem EDGE Wireless Modem offers SMS features such as text and PDU, point-to-point (MT/MO) and cell broadcast.

Industry-standard Modem Commands. The MultiModem EDGE Wireless Modem accepts industry-standard AT-style commands so that the MultiModem can be integrated easily into your existing software application.

Industrial Chassis. The MultiModem EDGE Wireless Modem is packaged in a rugged, water resistant, industrial chassis. The chassis has an RS-232 DE-15 Voice/Data interface connector and a permanent screw-type power connector. It also has an SMA antenna connector. The chassis can be side-mounted on a panel or top-mounted on a desktop or other surface. A set of LEDs indicates the modem's operational status.

Packet-Switched Data. The MultiModem EDGE Wireless Modem supports EDGE Class 10 packet-switched cellular data. It links the mobile cellular network to the Internet at speeds up to 240 kbps. Any service that is used over the fixed Internet today – File Transfer Protocol (FTP), web browsing, chat, e-mail, telnet -- is available over the cellular network, as well. The MultiModem EDGE supports PBCCH and coding schemes CS1 to CS4, and is compliant with SMG31bis.

Circuit-Switched Data (CSD). The MultiModem EDGE Wireless Modem also supports GSM circuit-switched cellular data connections. Circuit-switched data connections support speeds up to 9600 bps, Class 1 Group 3 fax. CSD cellular wireless connections are ideal for applications that require a quick wireless replacement of an existing point-to-point analog dial-up connection. They integrate seamlessly with your current application requiring little infrastructure change.

Internet-Enabled. The MultiModem EDGE Wireless Modem includes an embedded TCP/IP protocol stack to bring Internet connectivity to any device. Using the embedded Internet protocols and the wireless connection to an IP network, it sends and receives data over the Internet. It can also serve a single web page in response to a web browser request.

Voice Features. The MultiModem EDGE supports telephony and Dual Tone Multi Frequency (DTMF) functionality. It also allows for emergency calls as well as echo cancellation and noise reduction (option). It supports full rate, enhanced Full Rate and Half Rate (FR/EFR/HR).

Comprehensive Service and Support. The Multi-Tech commitment to service means we provide a two-year product warranty and service that includes technical support, 24-hour web site, and ftp support.

Safety

General Safety

The modem is designed for and intended to be used in fixed and mobile applications. “Fixed” means that the device is physically secured at one location and is not able to be easily moved to another location. “Mobile” means that the device is designed to be used in other than fixed locations.

Caution: Maintain a separation distance of at least 20 cm (8 inches) is normally maintained between the transmitter’s antenna and the body of the user or nearby persons. The Modem is not designed for or intended to be used in portable applications within 20 cm. (8 inches) of the body of the user.

RF Interference Issues

It is important to follow any special regulations regarding the use of radio equipment due in particular to the possibility of radio frequency, RF, interference. Please follow the safety advice given below carefully.

- Switch OFF your Wireless MultiModem when in an aircraft. The use of cellular telephones in an aircraft may endanger the operation of the aircraft, disrupt the cellular network and is illegal. Failure to observe this instruction may lead to suspension or denial of cellular telephone services to the offender, or legal action or both.
- Switch OFF your Wireless MultiModem when around gasoline or diesel-fuel pumps and before filling your vehicle with fuel.
- Switch OFF your Wireless MultiModem in hospitals and any other place where medical equipment may be in use.
- Respect restrictions on the use of radio equipment in fuel depots, chemical plants or where blasting operations are in progress.
- There may be a hazard associated with the operation of your Wireless MultiModem close to inadequately protected personal medical devices such as hearing aids and pacemakers. Consult the manufacturers of the medical device to determine if it is adequately protected.
- Operation of your Wireless MultiModem close to other electronic equipment may also cause interference if the equipment is inadequately protected. Observe any warning signs and manufacturers’ recommendations.

Vehicle Safety

- Do not use your MultiModem while driving.
- Respect national regulations on the use of cellular telephones in vehicles. Road safety always comes first.
- If incorrectly installed in a vehicle, the operation of Wireless MultiModem telephone could interfere with the correct functioning of vehicle electronics. To avoid such problems, be sure that qualified personnel have performed the installation. Verification of the protection of vehicle electronics should be part of the installation.
- The use of an alert device to operate a vehicle’s lights or horn on public roads is not permitted.

Maintenance of Your Modem

Your Wireless MultiModem is the product of advanced engineering, design and craftsmanship and should be treated with care. The suggestions below will help you to enjoy this product for many years.

- Do not expose the Wireless MultiModem to any extreme environment where the temperature is above 50°C or humidity is above 90% noncondensing.
- Do not attempt to disassemble the Wireless MultiModem. There are no user serviceable parts inside.
- Do not expose the Wireless MultiModem to water, rain, or spilled beverages. It is not waterproof.
- Do not place the Wireless MultiModem alongside computer discs, credit or travel cards, or other magnetic media. The phone may affect the information contained on discs or cards.
- The use of accessories not authorized by Multi-Tech or not compliant with Multi-Tech’s accessory specifications may invalidate the warranty of the Wireless MultiModem.
- In the unlikely event of a fault in the Wireless MultiModem, contact Multi-Tech Tech Support.

Your Responsibility

This Wireless MultiModem is your responsibility. Please treat it with care respecting all local regulations. It is not a toy. Therefore, keep it in a safe place at all times and out of the reach of children.

Try to remember your Unlock and PIN codes. Become familiar with and use the security features to block unauthorized use and theft.

Package Contents

Single Package (one unit)	Bundled Package (multiple units)
1 modem 1 mounting bracket 1 fused DC power cable 1 Quick Start Guide Note: You must supply: Screws for the bracket An antenna	<i>Each individual package in the bundle includes the following:</i> 1 modem 1 mounting bracket 1 RS232 cable (15-to-9 pin) 1 antenna 1 power supply (cord with international plug) 4 rubber feet Note: You must supply screws for the bracket.

Parts to be Supplied by Wireless Service Provider

Subscriber Identity Module (SIM) configuration chip
 The SIM contains information specific to your wireless account and its features.

Specifications

General Specifications	
Power Requirements	5 V to 32VDC; 400mA Average @5V, 1A Peak @ 5V
Circuit Switched Data/Fax Features	Asynchronous, non-transparent up to 14.4K bps Group 3 Fax, Class1
Mechanical Dimensions & Weight	4.3" L x 2.4" W x 0.94" H; 4.2 oz. (11 cm x 6.1 cm x 2.4 cm; 119 g)
Connectors & Fasteners	Antenna Connection type: Standard 3V SIM receptacle Serial Connector: 15-pin RS232 SUB D female (DE15S) Pins: RS232 link, audio link, BOOT, RESET Power Connector: 2.5mm miniature power jack (screw-on)
Operating Temperatures	-30° to +65°C
Storage Temperature	-40° to +85°C
Humidity	Relative humidity 20% to 90% noncondensing
Certifications	CE Mark, R&TTE EMC: FCC Part 2, 15 Class A, 22, 24, EN 55022 & EN 55024 Safety: cUL, UL 60950, EN 60950 Network: PTCRB

Electrical Characteristics	
Switching the GSM modem on/off	The device is permanently powered (when connected to the power supply).
Voltage Range	Voltage range : 5 to 32V DC GND : 0V
Over voltage and Under voltage	Correct operation of the Wireless MultiModem in communication mode is not guaranteed if input voltage falls below 5V.

Input/output electrical characteristics for external connections							
Parameters	GSM/GPRS 850/900			GSM/GPRS 1800/1900			Unit
	Typ.			Typ.			
Input Supply Voltage	5	13.2	32	5	13.2	32	V
Input peak supply current in comm. mode at P _{max}	1	.4	.2	1	.4	.2	A
Input average supply current in comm. mode at P _{max}	360	150	75	300	125	70	mA
Input average supply current in idle mode	30	10	10	30	10	10	mA

Antenna/RF Specifications

	GSM 850	EGSM 900
Frequency RX	869 to 894 MHz	925 to 960 MHz
Frequency TX	824 to 849 MHz	880 to 915 MHz
RF Power Stand	2W at 12.5% duty cycle	2W at 12.5% duty cycle
Impedance	50 ohms	
VSWR	<2	
Typical Radiated Gain	0 dBi on azimuth plane	

	GSM 1800	GSM 1900
Frequency RX	1805 to 1880 MHz	1930 to 1990 MHz
Frequency TX	1710 to 1785 MHz	1850 to 1910 MHz
RF Power Stand	1W at 12.5% duty cycle	1W at 12.5% duty cycle
Impedance	50 ohms	
VSWR	<2	
Typical Radiated Gain	0 dBi on azimuth plane	

Interfaces

The Wireless MultiModem has several interfaces:

- LED function indicating operating status
- External antenna (via SMA connector)
- Serial and control link (via 15 pins SUB D)
- Power supply (via 2.5mm miniature power jack)
- SIM card holder

LEDs

TD	Transmit Data. Lit when modem is transmitting data.
RD	Receive Data. Lit when modem is receiving data.
CD	Carrier Detect. Lit when data connection has been established.
LS	Line Status. Continuous “on” state indicates that the wireless modem is not registered on the network. Flashing state indicates registration on network. Off state. Modem is off (not ready) or in download mode.
TR	Terminal Ready. Commonly called “Data Terminal Ready.” This is a readiness signal from the PC.
PWR	Power. Indicates presence of DC power when lit.

RS232 15-Pin Connector Pinout

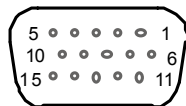

	PIN	EIA	CCIT	Designation
RS-232	1	DCD	109	Data Carrier Direct
	6	RX	104	Receive Data (out)
	2	TX	103	Transmit Data
	8	DTR	108.2	Data Terminal Ready
	9	GND		Signal Ground
	7	DSR	107	Data Set Ready
	12	RTS	105	Request to Send
	11	CTS	106	Clear to Send
	13	RI	125	Ring Indicator
Audio	4	MICROPHONE (+)		
	5	MICROPHONE (-)		
	10	SPEAKER (+)		
	15	SPEAKER (-)		
Boot	3	BOOT		For factory use only.
Reset	14	RESET		To reset, connect to GND for minimum of 20msec. Open for normal operation.

AT Command Information

AT commands for the EDGE wireless modem are published in a separate Reference Guide included on the MultiModem CD and posted on the Multi-Tech web site.

Chapter 2 – Activation and Installation

Step 1 – Activate Your Wireless Account

Multi-Tech – A Certified National Activation Agent

Multi-Tech Systems, Inc. is a certified national activation agent for Cingular and Sprint wireless. For more information about available data plans and to purchase and activate a wireless data account, contact Multi-Tech at 888-288-5470.

Pre-Configured Multi-Tech Products

Each Multi-Tech wireless product has been pre-configured to operate on a wireless network.

Activate Your Wireless Account

Please see the wireless account Activation Notices located on the MultiModem CD. Choose the one for your wireless network provider and follow the directions to activate your account.

Phone Numbers for the Wireless Modem

Every wireless modem will have its own unique phone number. The phone number may simply be given to you by your wireless service provider or it may be on the SIM card or both. Wireless provider implementations may vary.

Step 2 – Insert the SIM Card into the Holder

The wireless MultiModem requires the power supply connection to begin operation. It also requires a SIM card (Subscriber Identity Module) to operate on a GSM network. To install the modem, do the following:

1. Using your fingernail or a small wedging tool (e.g., a small screwdriver), pry off the SIM cover.

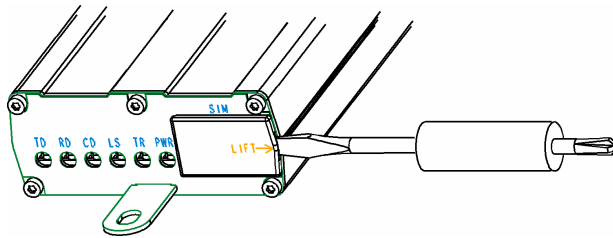

2. Insert the SIM card into the holder.

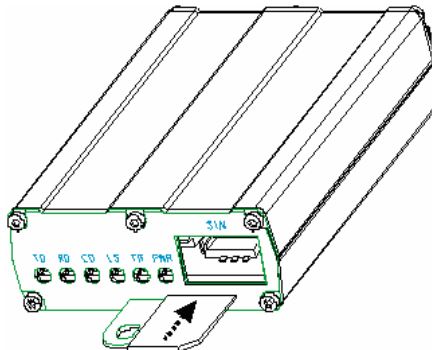

3. Verify that the SIM card fits into the holder properly and then replace the cover.

Step 3 – Hook up the Antenna, Serial Cable, and Power

Antenna

Connect a suitable antenna to the SMA connector (see specifications on page 8).

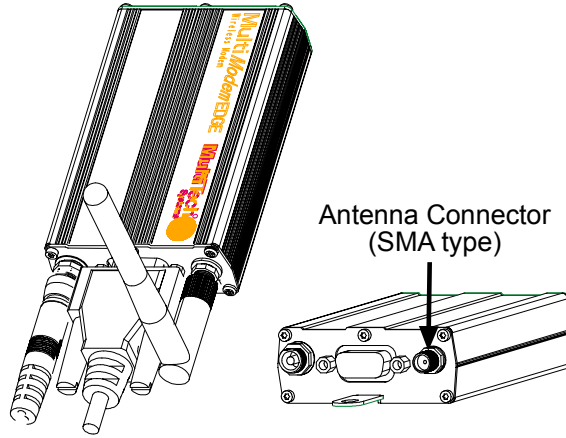

Serial Cable

Connect both sides of the serial and control cable (15-pin Sub D connector on the modem side).

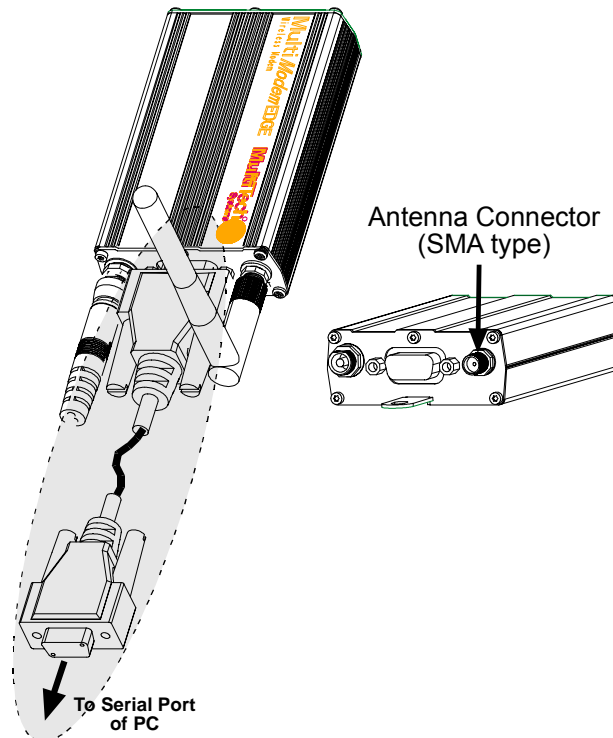

Power

Plug the power supply cable into the modem.

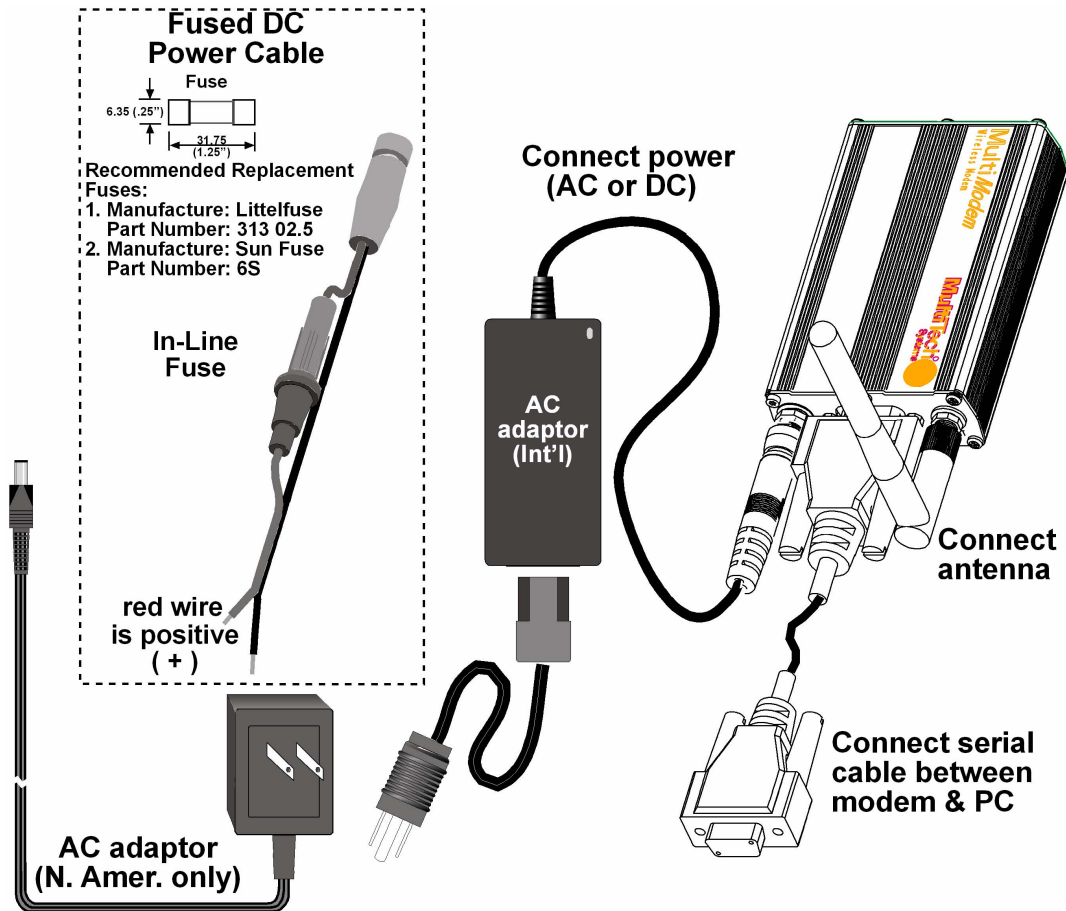

For two-piece transformer power supply (International).

- Connect the AC cord receptacle into the transformer block.
- Connect the AC cord plug into the mains power outlet.

For one-piece transformer power supply (North America).

- Connect between the MultiModem power receptacle and the mains power outlet.

For optional direct-DC powering.

- Connect the direct-DC power supply cable into the DC power source on the vehicle or machine in which you are mounting the modem. Be sure the GND connection is correct.
- Connect red wire to + (positive) and black wire to – (negative).

Note: For automotive application: according to the type of application, you can use permanent “+” or key-switched “+”. Connect the power supply to its source (for example, in a mobile situation, to the vehicle’s DC fuse/terminal block).

Warning: Do not connect your wireless modem directly to a vehicle’s battery for your power source. Doing so may cause power spikes. If you wish to use the battery as a power source, add a filtering device to the DC input.

Step 4 – Optional – Attach the Modem to a Flat Surface

To mount the Wireless MultiModem, do the following:

1. Obtain mounting screws (two are needed) that are appropriate for the surface on which you will mount the modem. For example, one might use two 6-32 self-tapping screws 5/8" in length to mount the unit in a truck to the wall of the cab behind the passenger's seat.
2. Typically, the unit is mounted against a flat surface into which holes can be drilled. The mounting holes (center-to-center) must be separated by 125mm or 4 -15/16 inches.

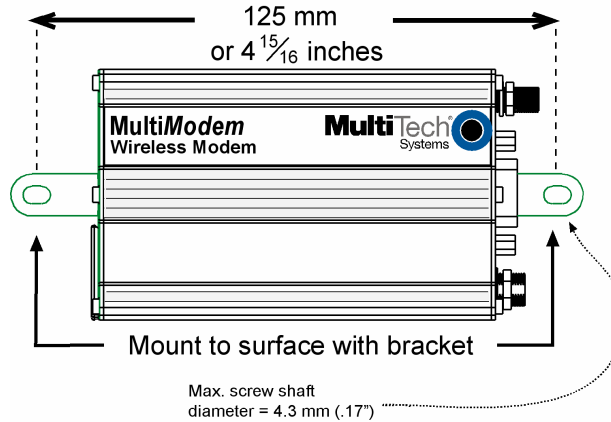

Drill the mounting holes at the desired mounting location (if applicable).

3. Slide the mounting brackets into the corresponding slots on the backside of the modem chassis.

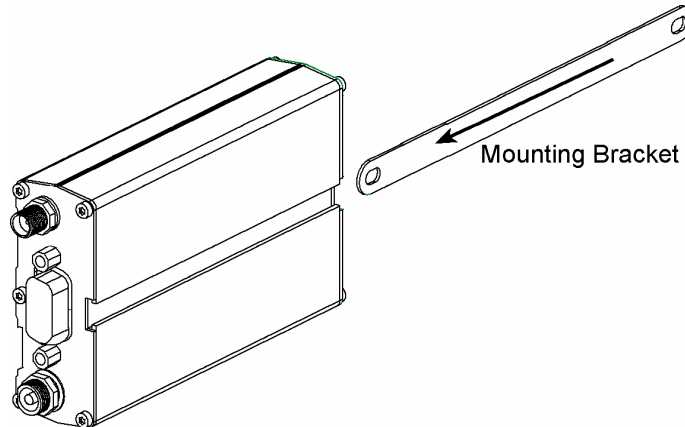

4. Attach the modem with two screws to the mounting surface at the desired location on the equipment.

Step 5 – Install the Modem Driver

Introduction

Compatibility: The wireless modem is compatible with Windows 2000/2003+, Windows XP, and Linux.

Windows: Windows operating systems require a modem driver to be installed. See the example below for installing an EDGE modem driver onto a PC with Windows XP/2003.

Linux: Linux does not require a driver for serial modems.

Requirements

- One MTCBA-E modem
- A RS232 cable to connect the modem to the PC
- The MultiModem CD that was shipped with the Multi-Tech modem
- A PC running Windows XP or Windows 2003

Note: This installation procedure is only used as a basic guide to help you install the Multi-Tech Wireless modem driver. You may see differences in your setup based upon your version of Windows and your Windows settings.

Installing the Multi-Tech MTCBA-E Modem Driver onto a PC Running Windows XP/2003

This installation assumes a Windows XP or 2003 operating system. XP and 2003 are identical in the methods they use for installing modem drivers.

To load the MultiModem wireless modem's driver on your PC, select the Control Panel's *Phone and Modem Options* option. During this installation, you will be required to browse the MultiModem CD to load the modem's INF file. This file is located at the root directory on the MultiModem CD.

1. Go to **Start**, and then click on **Control Panel**.
2. In the Control Panel, double-click on **Phone and Modem Options**. When the *Phone and Modem Options* screen appears, click on the tab labeled **Modems**.
3. Click on **Add** to add a new modem.
4. On the *Install Modem* screen, click **Don't detect my modem, I will select it from a list**. Then click **Next >**.
5. On the next screen, click the **Have Disk** button to browse for the driver file on the MultiModem CD.
6. Make sure that the Multi-Tech system CD is inserted into your CD-ROM then click on **Browse**.
7. Browse to the root directory of your CD-ROM drive and then click on **Open**.
8. The *Install From Disk* screen should now show the directory of your CD-ROM. Click on **OK**.
9. On this next screen, scroll down the list of modems and select the model that is applicable to your modem. Once you have selected your model, click on **Next>**.
10. You will now have to choose which com port the Multi-Tech modem is connected to. If you know exactly which port your modem is on, click on that port; other wise, choose COM1 (most common). Click **Next >**.
11. You will now be prompted with a screen that states that the Multi-Tech driver has not passed Windows logo testing. You can ignore this message and click **Continue Anyway**.
12. To finish the install, click on **Finish**.

You have now successfully installed the Multi-Tech wireless modem driver to your PC.

Verifying That Your Modem Has Been Installed Successfully

1. After you have successfully installed the Multi-Tech modem driver as stated above, you should be brought back to the *Phone and Modems Options* screen. Make sure that the modem is now listed under the columns **Modem** and **Attached To** (the correct com port).
2. Highlight the modem and then click on **Properties**.
3. A **Properties** screen will open for the Multi-Tech modem. Click on the tab labeled **Diagnostics**.
4. In the middle of the screen, click on the **Query Modem** button. Windows will now try to query the Multi-Tech modem. If this process passes, the second box on this screen will show the columns **Command** and **Response**.
Note: To make sure that the modem is correctly being queried, look at the LED lights of the modem after you click on *Query Modem*. The TR light should come on and the TD and RD lights should flicker.
5. If this process passes, then the modem should be properly installed and ready for use. Click **OK** to close the modem *Properties* window. Then click on **OK** to close the *Phone and Modem Options* window.

Chapter 3 – Using Your Wireless Modem

Phone Number for the Wireless Modem

- Every wireless modem will have its own unique phone number provided by your wireless provider.
- The wireless modem's phone number may simply be told to the subscriber or be on the SIM or both. Wireless provider implementations may vary.

Examples of Useful AT Commands

A Note About HyperTerminal

In order to verify signal strength and roaming status, you must use a terminal application such as HyperTerminal. To open this program in Windows XP or Windows 2003, go to **Start > All Programs > Accessories > Communications > HyperTerminal**. Other Windows operating systems have similar paths to HyperTerminal. See your system's online Help if you cannot find it.

A Note About AT Commands

AT commands can be used to operate, configure, and query your modem. A reference guide to the EDGE commands is included on the MultiModem CD and on the Multi-Tech Web site.

The following two commands let you query signal strength and roaming status.

Verify Signal Strength

Using HyperTerminal, type **AT+CSQ**

The modem responds with the received signal strength (rssi) and the channel bit error rate (ber).

RSSI ranges from 0 to 31.

BER ranges from 0 to 7 (7 is the highest error rate).

Signal Strength – RSSI	
10 - 31	Sufficient
0 - 9	Weak or Insufficient
99	Insufficient

Checking Network Registration and Roaming Status

Using HyperTerminal, type **AT+CREG?**

The modem will respond in one of the following ways:

- +CREG: 0,0 (this tells you that the modem is not registered on any network)
- +CREG: 0,1 (this tells you that the modem is registered on the home network)
- +CREG: 0,5 (this tells you the modem is registered on a network but it is roaming)

Note: If the modem is showing *not registered*, perform the procedure for verifying signal strength to determine the strength of the received signal.

Checking the Modem's Identity

Use the **ATI** command (Note: This command is illustrated using the capital letter i after **AT**)

- Type **ATI**
Product information displays. For example, Siemens MC75 Revision xx.yy (xx.yy is the software version)

Establishing a Voice Call

- **Enter PIN Code (Enter this only if required by your wireless provider)**

Type **AT+CPIN=1234**

Responses: OK (PIN Code accepted)
 +CME ERROR : 16 (Incorrect PIN Code)
 +CME ERROR : 3 (PIN already entered [with +CMEE : 1 mode])

- **Initiate a voice call**

Type **ATD1234;** (Note: Don't forget the semicolon “;” at the end. This stands for *voice* calls)

Responses: OK (Communication established)
 CME ERROR : 11 (PIN Code not entered [with +CMEE : 1 mode])
 CME ERROR : 3 (Operation not allowed)

- **Initiate an emergency call**

Type **ATD112;** (Note: Don't forget the semicolon “;” at the end. This stands for *voice* calls)

Responses: OK

- **Hang up**

Type **ATH**

Responses: OK

Establishing a Circuit-Switched Data Call for a Point-to-Point Connection

A Circuit-Switched Data Connection (CSD) makes the wireless modem work similar to a regular analog modem. You must have CSD service in order to make a CSD call. Note that your wireless provider charges airtime usage for these connections.

Note: Your wireless service provider charges airtime usage for these connections.

1. Using HyperTerminal, you can establish a CSD connection by entering the following command:

ATD<phone number>

Notes:

- The phone number you are calling is entered between the brackets. For example, <8585551212>
- This command tells the modem to dial the desired phone number. If you are dialing to another modem, the modem should answer and a connection between the two modems will be established.

2. To disconnect, use the following commands:

+++ Wait about two seconds to see an OK response. Then type:

ATH

Note: **+++** is the escape sequence and **ATH** is the Hang-up command.

Answering a Circuit-Switched Data (CSD) Connection

A Circuit-Switched Data Connection makes the wireless modem work similar to a regular analog modem. You must have CSD service in order to answer a CSD call.

There are three phone numbers for GSM: the voice number, the data number, and the fax number. All are provided by the carrier. To answer a call:

Establish A Connection: Call into the modem by dialing the data number provided by your carrier.

Answer a Call: When you see the RING responses on the terminal screen, enter **ATA <cr>** to answer the call.

Set Auto-Answer: Enter **ATS0=x**
 This sets the modem to auto-answer. The call will be answered after the number of rings entered. **x** stand for the number rings.
 Then call into the number provided to you by the carrier.

Disconnect: Type: **+++**
 Wait about one second to see an OK response.
 Then type: **ATH**

Using Short Message Service (SMS)

If you have SMS (Short Message Service), you can manipulate such messages in these ways: send, read, store, and delete. The AT commands needed to perform these functions are listed below. Please refer to the EDGE AT Command Reference Guide for a complete list and definitions of the SMS commands.

1. Send a short message to a specified number.

Type **AT+CMGS="8585551212" <press Enter>**

Wait for the ">" before entering text.

Then type your message:

Please call me soon. <press ctrl Z>

The modem may respond with **+CMGS:<mr> OK**

2. Write a message to memory.

You can store a message to send it at a later date.

Type **AT+CMGW="8585551212" <press Enter>**

Wait for the ">" before entering text.

Then type your message:

Please call me soon. <press ctrl Z>

The modem may respond with **+CMGW: <index>** (The index number will be given)

3. Send a message from storage.

Type **AT+CMSS=x <press Enter>**

The modem may respond with **+CMSS: 1 OK** (The transmission is successful. One SMS message is sent.)

Note: The **x** represents an index location.

4. View a list of stored messages.

Type **AT+CMGL=x <press Enter>**

For **x**, substitute one of the following:

"REC UNREAD" Shows unread messages.

"REC READ" Shows read messages.

"STO UNSENT" Shows unsent messages.

"STO SENT" Shows sent messages.

"ALL" Shows all messages.

The modem will respond **AT+CMGL: 1,"REC UNREAD","8585551212",1...**

The modem will continue until all UNREAD messages, numbers, and index number are listed.

5. Read a stored message.

Type **AT+CMGR=x <press Enter>**

The modem may respond with **+CMGR: "REC READ", "8585551212",**

Note: The **x** represents an index location.

6. Delete a stored message.

Type **AT+CMGD=x <press Enter>**

The modem will respond **OK**.

Note: The **x** represents an index location.

SMS Examples

Send Example: Send SMS message to another SMS compatible device:

```

at+cmgf=1 (set to text mode)
OK

at+cpms="SM","SM","SM" (set memory storage when writing and sending SMS messages)
OK

at+cmgs="7632273726" (send message to the number specified in quotes)
> TEST message ONE. (Type message after the > symbol and hit <CTRL + Z> to send the message)
+CMGS: 52

OK

```

Receive Example 1: Receive SMS messages in text mode by saving to SIM memory – Notification via +CMTI unsolicited response code:

```

at+cmgf=1 (set to text mode)
OK
at+cnmi=2,1,0,0,1 (set to receive SMS and store to memory)
OK
at+cpms="SM","SM","SM" (set messages to be read from SIM and stored to SIM card)
OK

+CMTI: "SM",1 (message received and stored to the SIM card to location 1)
at+cmgr=1 (read the message in location 1)
+CMGR: "REC UNREAD","+17632273726",,"06/03/17,09:02:52+00"
TEST SMS 1 (message)

OK

at+cmgd=1 (delete message in location 1)
OK

```

Receive Example 2: Receive SMS message in text mode by directly routing the received message to the TE through the serial port:

```

at+cmgf=1 (set to text mode)
OK
at+csms=1 (set to Phase 2+ compatibility)
+CSMS: 1,1,1

OK
at+cnmi=2,2,0,0,1 (set to receive SMS messages and directly route to TE)
OK
+CMT: "+17632273726",,"06/03/17,09:06:11+00"
TEST SMS 2 (message)
at+cnma (acknowledge to the network that the message has been received)
OK

```

Internet Access

Internet access can be setup in Windows Dial-Up Networking (DUN) of the computer that the wireless modem is serving. Setup procedures will vary according to the type of wireless service provider used. To access *Dial-Up Networking* on your PC, go to **Start > Settings > Network Connections**.

Notes:

- For GSM-without-GPRS, a circuit-switched data connection is used. The user can set up Dial-Up Networking (DUN) to make a conventional V.32 modem connection to any terminating modem at the other end. The phone number specified in DUN can be one supplied by the wireless service provider or another phone number related to a different dialup modem service (e.g., a dialup modem service phone number from any commercial or private dialup network).
- For GSM-with-GPRS, a single DUN number is generally used by all of a wireless provider's subscribers throughout its area of coverage (regional, nationwide, continental, etc.). Rather than being a literal phone directory number, as in conventional DUN, this is a code that gives the modem Internet access.

Connecting to the GPRS/EDGE Network for Internet Access

After you have inserted the SIM card and all other setup steps are complete, you can establish an Internet connection through a Windows dial-up session.

Note that your wireless provider will charge you for data usage.

Requirements

- One Multi-Tech wireless EDGE modem
- The EDGE modem should have an active SIM card and must have GPRS/EDGE services
- The modem must be getting a proper signal and be showing a network registration through the wireless provider's network
- A PC running Windows XP or Windows 2003 with the Multi-Tech drivers installed for your particular model

The following instructions are for Windows XP SP2 and Windows 2003. Every PC may have slight differences which may cause the instructions to be different. Use these instructions as a guide to help you understand what is required to set up an Internet connection through your wireless service provider for all operating systems.

Note: Cellular providers provide Internet services as part of your service plan. Multi-Tech recommends that if you plan on using large amounts of data, to sign up for an unlimited data service plan with your provider. Multi-Tech Systems, Inc. will not be responsible for any charges on your cellular bill. If you have any questions about billing, service plans, service charges, etc., please contact your provider for more information.

Set the Access Point Name (APN) into the Modem's Properties on Your PC

In order for your EDGE wireless modem to connect to your provider's network, you must tell the modem the Access Point Name (APN) to which it will connect. The APN is a server name that your account is setup on with your provider. Your APN will be given to you by your provider. Here are some well-known APNs:

- Cingular Wireless: ISP.CINGULAR, or WAP.CINGULAR
- Cingular Wireless (Formerly AT&T): PROXY, or INTERNET, or PUBLIC
- T-Mobile: INTERNET2.VOICESTREAM.COM, or INTERNET3.VOICESTREAM.COM, or WAP.VOICESTREAM.COM
- Rogers AT&T of Canada: INTERNET.COM

Steps for Setting the APN

1. Start by clicking on **Start** and then clicking on **Control Panel**.
2. In the Control Panel, double-click on **Phone and Modem Options**.
3. The *Phone and Modem Options* window appears. Click on the tab labeled **Modems**. Highlight the Multi-Tech wireless modem listed in the table and then click on **Properties**.
4. A *Properties* window for your modem will display. Click on the **Advanced** tab and you should see an *Extra Settings* box. In the **Extra initialization commands** text box, type:

AT+CGDCONT=1,"IP", "<APN>"

For <APN>, type in the correct APN for your account. For example:

AT+CGDCONT=1,"IP", "ISP.CINGULAR"

Click **OK** to close the modem *Properties* window. Then click **OK** to close the *Phone and Modem Options* window.

Create Your Dial-Up Connection in Windows XP/2003

1. Click on **Start** and then click on **Control Panel**.
2. In the *Control Panel*, double-click on **Network Connections**.
3. On the *Network Connections* screen on the left-hand side under **Network Tasks**, click on **Create a new connection**.
4. The *New Connection Wizard* should appear. It will walk you through setting up your Internet connection. Click on **Next >** to begin.
5. On the *Network Connection Type* screen, select **Connect to the Internet**, and then click **Next >**.
6. On the *Getting Ready* screen, select **Set up my connection manually**, and then click **Next >**.
7. On the *Internet Connection* screen, select **Connect using a dial-up modem**, and then click **Next >**.
Note: After clicking on Next, you may or may not be asked to select which modem to use. If you have more than one modem installed in your PC, you will be required to select the proper modem to use. If asked, please select the Multi-Tech wireless modem that has been installed.
8. On the *Connection Name* screen in the **ISP Name** box, type in a name for your new connection. You can give it any name that you would like. After you have typed in a name, click **Next >**.
9. On the *Phone Number to Dial* screen, type in the number that specifies to the modem to connect to your provider's Internet service.
 For EDGE modems, type in the number ***99***1#**.
 Then click **Next >**.
10. On the *Connection Availability* screen, specify if this connection is for anyone's use or for your use only by checking the appropriate button. Choose your preference, and then click **Next>**.
11. On the *Internet Account Information* screen, type the user name and the password for your account. In many cases, a user name and a password are not required, but some wireless providers require it. Check with your provider to see if they are needed.

Here is some helpful information:

- **For Cingular accounts using the ISP.CINGULAR APN:**
 User name: ispda@cingulargprs.com
 Password: CINGULAR1
- **For Cingular accounts using WAP.CINGULAR APN:**
 User name: wap@cingulargprs.com
 Password: CINGULAR1
- **All other APNs listed on the previous page may not require user names and passwords.**

Check the following two options if you would like them activated:

Check the box if you want this account name and password to be used by everyone.

Check the box if you want this as your default Internet connection. Then click **Next >**.

12. On the *Completing the New Connection Wizard* screen, your last task is to place a check in the box if you would like to add a shortcut to your desktop. Then click **Finish**.
13. A *Connection* screen displays on your desktop. Click the **Properties** button on the bottom of this screen.
14. The *Properties* window will open for you to make your connection. **Important:** Make sure that *Use dialing rules* is not selected, and then click **OK**.
15. Once back at your *Connection* screen, click the **Dial** button at the bottom of the screen to start the connection.
16. The connection will now tell the modem to connect to your provider's Internet service. Once connected, you should see the connection status icon in your system tray at the bottom right-hand corner of your screen.
 You should now be able to open Internet Explorer or any other browser of your preference to surf the Internet.

Disconnecting the Connection:

1. To disconnect the connection, right click on the connection icon in your system tray at the bottom right-hand corner of your screen.
2. Scroll up and click on **Disconnect**.
 You should now be disconnected from the Internet.

Mobile PhoneTools

Mobile PhoneTools is a communication software program included on your MultiModem CD. You can install this program onto your PC and use it for making Internet connections, voice calls, SMS messaging, and email. This program allows you to use your wireless modem hooked up to your PC as if it were a cell phone. At the moment, Mobile PhoneTools does not function properly with EDGE models. We are sorry for this inconvenience.

Chapter 4 – Troubleshooting and Frequently Asked Questions

Troubleshooting Examples

Before calling the Multi-Tech Technical Support, check to the following connections:

- The right antenna is connected to the modem
- The serial cable connection is correct
- The power is connected correctly and the power lights on the modem are on
- Verify your signal strength
- Verify your network registration
- Use the following situation examples to troubleshoot the modem not answering and the modem returning a *No Carrier* message.

Situation A: The modem does not answer

If the Wireless MultiModem does not answer through the serial link upon an attempted transmission of data or voice signals, see the table below for possible causes and solutions.

Solutions for 'no connection through serial link' situation		
If the modem returns ...	Then ask ...	Action
(nothing)	Is the communication program properly configured?	In communications program, verify that modem parameters have been set to the values shown here: Data bits = 8 Parity = none Stop Bits = 1 Baud = 115200 bps
	Is another program interfering with the communication program?	Close any such application program.
	Is the modem set to autoanswer?	Type ATS0=1 (to set to auto answer on the first ring) Type ATA (to set to manual answer)
	Is the communication program receiving RING responses?	Type ATS0=1 (to set to auto answer on the first ring) Type ATA (to set to manual answer)

Situation B: The modem always returns «No carrier» when trying to originate a call

Solutions for "no carrier" message		
If the modem returns ...	Then ask ...	Action
no carrier (esp. for data communication)	Is the selected bearer type supported by the called party?	Type AT+CEER to view the extended error code (see "Error Results Codes" in the AT Command guide). Be sure that the selected bearer type is supported by the called party.
	Is the selected bearer type supported by the network?	Be sure that the selected bearer type is supported by the network. If no success, try bearer selection type: AT+CBST=0,0,3 Be sure SIM card is available for data/fax calls.
no carrier (esp. for voice communication)		Be sure that the semicolon character (";") is typed immediately after the phone number in the AT command; e.g., ATD#####;

Frequently Asked Questions

Which providers can I use?

- Two major providers are T-Mobile and Cingular.
- We are Cingular approved.

Does this modem support High-Speed Circuit-Switched Data (HSCSD)?

- No, our EDGE modems do not support HSCSD.

The modem is answering, but seems to not be doing anything?

- The modem is answering in voice mode.
- If you are trying to make a data call, make sure the account has CSD service. You will also need the data number (separate number from the main phone number that is provided by the provider).

I am trying to make a data connection by dialing from my wireless modem to an analog modem. Why does the analog modem answer and send tones, but never connect?

- To make a data call you must use the ATD<number> command.
- Make sure the account has CSD service.

How do I get the voice portion to work so I can talk to others using the wireless modem?

- You will need a cable that has the speaker pins connected to a speaker and microphone.
- We have a “Y” cable that splits out to an RJ9 connector; it can be used to plug into the receiver of a handset.
- ‘ATD<number>;’ will originate a voice call.

How do I make an Internet connection to my dial-up ISP?

- Make sure you have CSD service.
- Create a dial-up connection to the ISP’s access number, then use your account username and password and choose the wireless modem as the device.

How does faxing work?

- EDGE modems support Class 1 Group 3 faxing.
- You will need fax services setup on your account. You should receive a separate phone number for fax just like voice and data, and you must call the fax number for the modem to receive a fax.
- You will also need fax software. WinFax Version 10 has been tested with success.

I can’t make outgoing calls. I just receive a NO CARRIER response.

- Make sure the antenna is connected and SIM is inserted correctly.
- Check signal and registration: ‘AT+CSQ’ (10-31 is good), ‘AT+CREG?’ (0,1 is registered & 0,5 is roaming).
- Check NO CARRIER reason with ‘AT+CEER’. Look up error code in Reference Guide.

The modem will not answer.

- To have modem autoanswer, set modem with ‘ATS0=1’ and ‘AT&W’ to store the setting.
- Send ‘ATA’ to the modem once the RING is indicated on the terminal screen.
- You may need to set modem to ignore DTR, ‘AT&D0’, if you aren’t providing DTR.

I am trying to make a GPRS/EDGE connection using a Windows dial-up session. It connects and then immediately disconnects.

- Make sure the APN is configured in the modem correctly (The APN is provided by the provider).
- Check the APN with ‘AT+CGDCONT?’ To make sure it is correct.
- If no APN is inserted, then insert the correct APN using the command ‘AT+CGDCONT=1,“IP”,“<APN>”’ with HyperTerminal or add it into the “Extra Initialization Commands:” in the modem’s properties.
- Make sure the APN is correct for your account.

When I try to establish a GPRS/EDGE connection using Windows dial-up I get an error: “Hardware Failure”.

- Check the modem to make sure it is installed and can be queried in the modem’s properties.
- Make sure the com port is not being held by another application. Look for the TR light indication. If it is on, most likely another application is holding onto the port.
- Make sure the dial-up connections maximum speed matches the modem’s properties maximum port speed.
- Try rebooting the PC.

What is the max serial baud rate that this modem supports?

- Supports up to 460,8000 bps.

Sometimes when I set the modem’s serial rate for auto-baud, it doesn’t respond to AT commands.

- This modem supports the auto-baud features, but it is currently not working reliably. The best option is to set the serial rate to the needed speed (+IPR command).

Why is it that when I set the APN to the modem using the +CGDONT command and then do an ATZ or recycle power to the modem, the APN is lost?

- The EDGE modem does not store this setting. The best option is to set this command string as an initialization command in your application. If you are using a Window dial-up connection, add this command to the “Extra Initialization” setting in the modem’s properties.

Why is it that my throughput rates are not matching up to the expected EDGE rates?

- To see maximum throughput rates on the EDGE models you must set the modem’s serial baud rate and your serial port rate to 230,400 bps and above.
- If your port supports only 115,200 bps, then you may not see expected EDGE rates.

Data Cable Diagram – with Voice

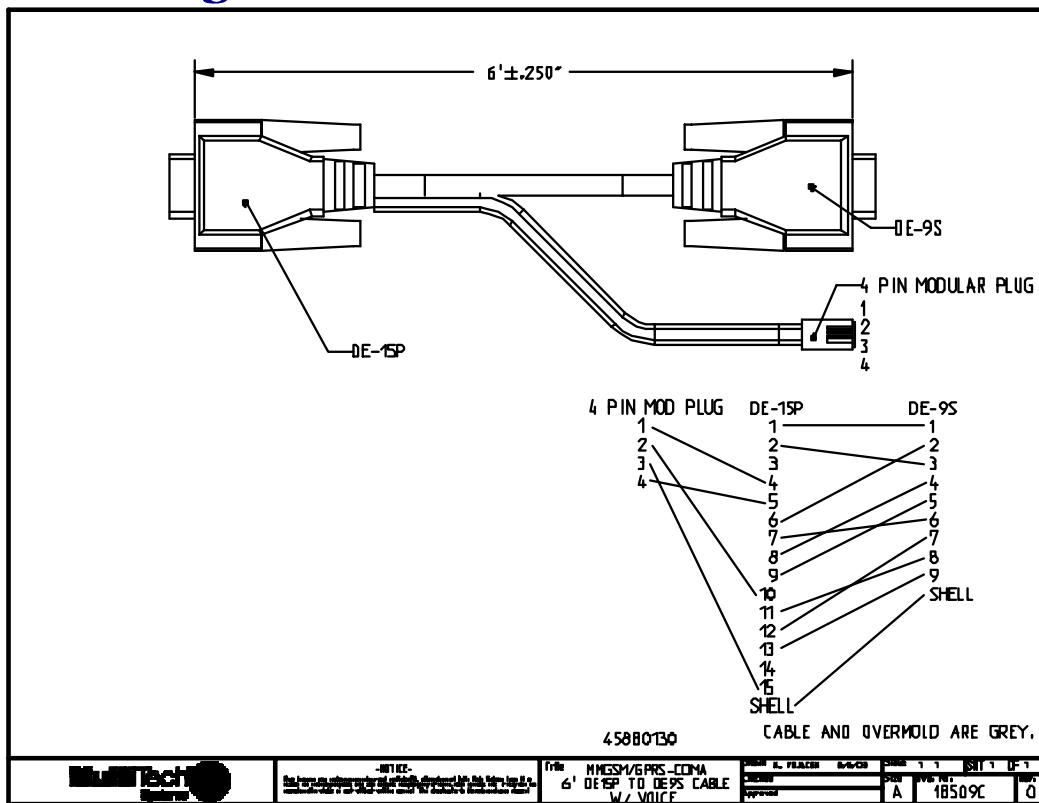

Fused DC Power Cable Dimensions How to Change the Fuse

The Fused DC power cable is provided when a single unit is purchased.

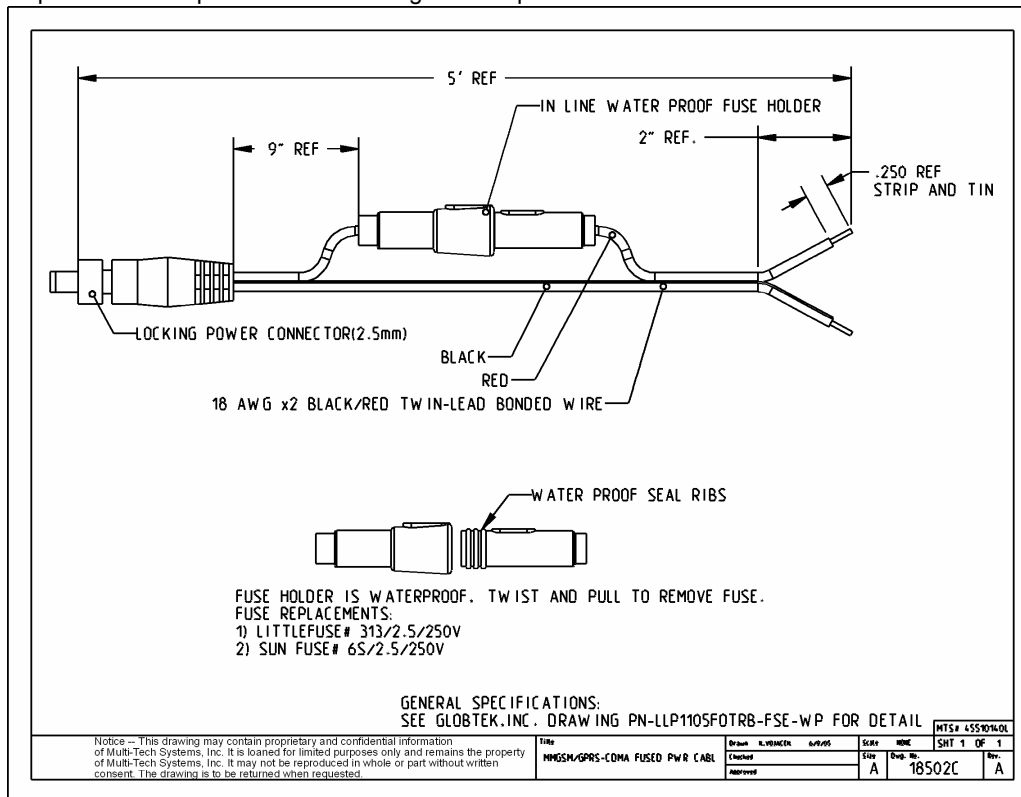

Appendix A – Warranty and Repairs

Multi-Tech Warranty Statement

Multi-Tech Systems, Inc., (hereafter “MTS”) warrants that its products will be free from defects in material or workmanship for a period of two, five, or ten years (depending on model) from date of purchase, or if proof of purchase is not provided, two, five, or ten years (depending on model) from date of shipment.

MTS MAKES NO OTHER WARRANTY, EXPRESS OR IMPLIED, AND ALL IMPLIED WARRANTIES OF MERCHANTABILITY AND FITNESS FOR A PARTICULAR PURPOSE ARE HEREBY DISCLAIMED.

This warranty does not apply to any products which have been damaged by lightning storms, water, or power surges or which have been neglected, altered, abused, used for a purpose other than the one for which they were manufactured, repaired by Customer or any party without MTS’s written authorization, or used in any manner inconsistent with MTS’s instructions.

MTS’s entire obligation under this warranty shall be limited (at MTS’s option) to repair or replacement of any products which prove to be defective within the warranty period or, at MTS’s option, issuance of a refund of the purchase price. Defective products must be returned by Customer to MTS’s factory — transportation prepaid.

MTS WILL NOT BE LIABLE FOR CONSEQUENTIAL DAMAGES, AND UNDER NO CIRCUMSTANCES WILL ITS LIABILITY EXCEED THE PRICE FOR DEFECTIVE PRODUCTS.

Repair Procedures for U.S. and Canadian Customers

In the event that service is required, products may be shipped, freight prepaid, to our Mounds View, Minnesota factory:

Multi-Tech Systems, Inc.
2205 Woodale Drive
Mounds View, MN 55112 U.S.A
Attn: Repairs, Serial # _____

A Returned Materials Authorization (RMA) is not required. Return shipping charges (surface) will be paid by MTS to destinations in U.S. and Canada.

Please include, inside the shipping box, a description of the problem, a return shipping address (must have street address, not P.O. Box), your telephone number, and if the product is out of warranty, a check or purchase order for repair charges.

For out of warranty repair charges, go to [COMPANY/Policies/warranty/](#)

Extended two-year overnight replacement service agreements are available for selected products. Please call MTS customer service at (888) 288-5470 or visit our web site at [COMPANY/Programs/overnight_replacement](#) for details on rates and coverage’s.

Please direct your questions regarding technical matters, product configuration, verification that the product is defective, etc., to our Technical Support department at (800) 972-2439 or email support@multitech.com. Please direct your questions regarding repair expediting, receiving, shipping, billing, etc., to our Repair Accounting department at (800) 328-9717 or (763) 717-5631, or email mtsrepair@multitech.com.

Repairs for damages caused by lightning storms, water, power surges, incorrect installation, physical abuse, or user-caused damages are billed on a time-plus-materials basis.

Repair Procedures for International Customers

(Outside U.S.A. and Canada)

Your original point of purchase Reseller may offer the quickest and most economical repair option for your Multi-Tech product. You may also contact any Multi-Tech sales office for information about the nearest distributor or other repair service for your Multi-Tech product. The Multi-Tech sales office directory is available at http://www.multitech.com/COMPANY/contact_us/

In the event that factory service is required, products may be shipped, freight prepaid to our Mounds View, Minnesota factory. Recommended international shipment methods are via Federal Express, UPS or DHL courier services, or by airmail parcel post; shipments made by any other method will be refused. Please include, inside the shipping box, a description of the problem, a return shipping address (must have street address, not P.O. Box), your telephone number, and if the product is out of warranty, a check in U.S. dollars drawn on a U.S. bank or your company's purchase order for repair charges. Repaired units shall be shipped freight collect, unless other arrangements are made in advance.

Please direct your questions regarding technical matters, product configuration, verification that the product is defective, etc., to our Technical Support department nearest you or email support@multitech.com. When calling the U.S., please direct your questions regarding repair expediting, receiving, shipping, billing, etc., to our Repair Accounting department at +(763) 717-5631 in the U.S.A., or email mtsrepair@multitech.com.

Repairs for damages caused by lightning storms, water, power surges, incorrect installation, physical abuse, or user-caused damages are billed on a time-plus-materials basis.

Repair Procedures for International Distributors

International distributors should contact their MTS International sales representative for information about the repair of the Multi-Tech products.

Please direct your questions regarding technical matters, product configuration, verification that the product is defective, etc., to our International Technical Support department at +(763)717-5863. When calling the U.S., please direct your questions regarding repair expediting, receiving, shipping, billing, etc., to our Repair Accounting department at +(763) 717-5631 in the U.S.A. or email mtsrepair@multitech.com.

Repairs for damages caused by lightning storms, water, power surges, incorrect installation, physical abuse, or user-caused damages are billed on a time-plus-materials basis

Replacement Parts

SupplyNet, Inc., can supply you with replacement power supplies, cables and connectors for selected Multi-Tech products. You can place an order with SupplyNet via mail, phone, fax or the Internet at the following addresses:

Mail: SupplyNet, Inc.
614 Corporate Way
Valley Cottage, NY 10989
Phone: 800 826-0279
Fax: 914 267-2420
Email: info@thesupplynet.com
Internet: <http://www.thesupplynet.com>

Appendix B – Waste Electrical and Electronic Equipment (WEEE) Statement

July, 2005

The WEEE directive places an obligation on EU-based manufacturers, distributors, retailers and importers to take-back electronics products at the end of their useful life. A sister Directive, ROHS (Restriction of Hazardous Substances) complements the WEEE Directive by banning the presence of specific hazardous substances in the products at the design phase. The WEEE Directive covers all Multi-Tech products imported into the EU as of August 13, 2005. EU-based manufacturers, distributors, retailers and importers are obliged to finance the costs of recovery from municipal collection points, reuse, and recycling of specified percentages per the WEEE requirements.

Instructions for Disposal of WEEE by Users in the European Union

The symbol shown below is on the product or on its packaging, which indicates that this product must not be disposed of with other waste. Instead, it is the user's responsibility to dispose of their waste equipment by handing it over to a designated collection point for the recycling of waste electrical and electronic equipment. The separate collection and recycling of your waste equipment at the time of disposal will help to conserve natural resources and ensure that it is recycled in a manner that protects human health and the environment. For more information about where you can drop off your waste equipment for recycling, please contact your local city office, your household waste disposal service or where you purchased the product.

